



ORIGINAL INSTRUCTIONS

Refer to Declaration of Conformity for relevant Directives



Instruction Manual

2 Port Valve for Compressed Air and Air-hydro Circuit Control

Series VNA



The intended use of this product is to control pneumatic systems or air-hydro circuits. A balance poppet enables air to flow forward or backward.

Refer to How to order for CE marked and/or validated components. Validated according to ISO13849, see section 2.

1 Safety Instructions

These safety instructions are intended to prevent hazardous situations and/or equipment damage. These instructions indicate the level of potential hazard with the labels of "Caution", "Warning" or "Danger". They are all important notes for safety and must be followed in addition to International Standards (ISO/IEC^{*)}, and other safety regulations.

- ^{*)} ISO 4414: Pneumatic fluid power - - General rules relating to systems.
- ISO 4413: Hydraulic fluid power - - General rules relating to systems.
- IEC 60204-1: Safety of machinery - -Electrical equipment of machines. (Part 1: General requirements)
- ISO 10218-1: Manipulating industrial robots -Safety. etc.

This manual contains essential information for the protection of users and others from possible injury and/or equipment damage.

- Read this manual before using the product, to ensure correct handling, and read the manuals of related apparatus before use.
- Keep this manual in a safe place for future reference.
- To ensure safety of personnel and equipment the safety instructions in this manual must be observed, along with other relevant safety practices.

	Caution	Caution indicates a hazard with a low level of risk which, if not avoided, could result in minor or moderate injury.
	Warning	Warning indicates a hazard with a medium level of risk which, if not avoided, could result in death or serious injury.
	Danger	Danger indicates a hazard with a high level of risk which, if not avoided, will result in death or serious injury.

Warning

- The compatibility of the product is the responsibility of the person who designs the equipment or decides its specifications.**
- Since the product specified here is used under various operating conditions, its compatibility with specific equipment must be decided by the person who designs the equipment or decides its specifications based on necessary analysis and test results. The expected performance and safety assurance of the equipment will be the responsibility of the person who has determined its compatibility with the product. This person should also continuously review all specifications of the product referring to its latest catalogue information, with a view to giving due consideration to any possibility of equipment failure when configuring the equipment.

1 Safety Instructions - continued

- Only personnel with appropriate training should operate machinery and equipment.**
The product specified here may become unsafe if handled incorrectly. The assembly, operation and maintenance of machines or equipment including our products must be performed by an operator who is appropriately trained and experienced.
- Do not service or attempt to remove product and machinery/equipment until safety is confirmed.**
 - The inspection and maintenance of machinery/equipment should only be performed after measures to prevent falling or runaway of the driven objects have been confirmed.
 - When the product is to be removed, confirm that the safety measures as mentioned above are implemented and the power from any appropriate source is cut, and read and understand the specific product precautions of all relevant products carefully.
 - Before machinery/equipment is restarted, take measures to prevent unexpected operation and malfunction.
- Contact SMC beforehand and take special consideration of safety measures if the product is to be used in any of the following conditions.**
 - Conditions and environments outside of the given specifications, or use outdoors or in a place exposed to direct sunlight.
 - Installation on equipment in conjunction with atomic energy, railways, air navigation, space, shipping, vehicles, military, medical treatment, combustions and recreation, or equipment in contact with food and beverages, emergency stop circuits, clutch and brake circuits in press applications, safety equipment or other applications unsuitable for the standard specification described in the product catalogue.
 - An application which could have negative effects on people, property, or animals requiring special safety analysis outside the scope of ISO 13849 described in this document.
 - Use in an interlock circuit, which requires the provision of double interlock for possible failure by using a mechanical protective function, and periodical checks to confirm proper operation.

- Always ensure compliance with relevant safety laws and standards.**
All electrical work must be carried out in a safe manner by a qualified person in compliance with applicable national regulations.

Caution

- The product is provided for use in manufacturing industries.**
The product herein described is basically provided for peaceful use in manufacturing industries. If considering using the product in other industries, consult SMC beforehand and exchange specifications or a contract if necessary. If anything is unclear, contact your nearest sales branch.

2 Specifications

2.1 Valve Specifications

Fluid	See Table 2	
Fluid temperature	VNA□□□A	-5 to 60 °C ^{Note 1)}
	VNA□□□B/ VNA□□□C	-5 to 99 °C ^{Note 1)} (Only air operated)
Ambient temperature	-5 to 50 °C (Air operated: 60°C) ^{Note 1)}	
Proof pressure	1.5 MPa	
Min. operating pressure	0	
Max. operating pressure	1 MPa	
External pilot air	Pressure range	0.2 to 0.7 MPa
	Lubrication	Not required (See also 3.4) ^{Note 2)}
	Temperature	-5 to 50 °C (Air operated: 60 °C)
Flow	See Table 3, Table 4	
Filtration	5 μm filtration or smaller	
Weight	See Table 5	
Vibration resistance	30 m/s ²	
Impact resistance	150 m/s ²	
Min. operating frequency	1 cycle/30 days	
Max. operating frequency	1 cycle/1 second	

2 Specifications - continued

Mounting orientation ^{Note 3)}	unrestricted
B ₁₀ ^{Note 4)}	2 million cycles
B _{10D} ^{Note 4)}	4 million cycles
Standards	Complies with the basic and well-tried safety principles of ISO 13849-2:2012

Table 1

Notes:

- Note 1) No freezing
- Note 2) Lubrication is not allowed in case of seal material EPR.
- Note 3) For external pilot solenoid, it is recommended that the pilot solenoid valve be oriented either vertically upward or horizontally.
- Note 4) Under SMC test conditions. The B₁₀ figure is estimated from SMC life tests. The B_{10D} figure is derived from B₁₀ using the assumption in EN ISO 13849-1:2015 Annex C. Contact SMC for details.

2.2 Pilot Solenoid Valve Specifications

Port Size	6A to 25A	32A to 50A
Pilot solenoid valve	SF4-□□□-23 SF4-□ ^D / _{DZ} -23-Q	VO307-□□□1 VO307-□ ^{D1} / _{DZ1} -Q
Electrical entry	Grommet, Grommet terminal Conduit terminal DIN terminal	Grommet, DIN terminal
Coil rated voltage (V)	AC (50/60 Hz)	100 V, 200 V Other voltage (Semi-standard)
	DC	24 V, Other voltage (Semi-standard)
Allowable voltage fluctuation	-15% to +10% of rated voltage	
Coil insulation	Class B or equivalent (130 °C)	
Temperature rise	35 °C or less (When rated voltage is applied)	50 °C or less (When rated voltage is applied)
	Inrush	5.6 VA (50 Hz), 5.0 VA (60 Hz)

Apparent power AC

Power consumption	Holding	3.4 VA (50 Hz), 2.3 VA (60 Hz)	7.6 VA (50 Hz), 5.4 VA (60 Hz)
	DC	1.8 W (without light), 2 W (with light)	4 W (without light), 4.2 W (with light)
Manual override		Non-locking push type Other (Semi-standard)	Non-locking push type

Table 2

Note: For validated types refer to section 5 'How to order.'

2.3 Applicable Fluids

Model	VNA□□□A (Valve material: NBR seal)	VNA□□□B (Valve material: FKM seal)	VNA□□□C (Valve material: EPR seal)
Fluid	Air (Standard, Dry) Carbon dioxide (CO ₂) (Less than 0.7 MPa) Nitrogen gas (N ₂) Turbine oil ^{Note 1)} Hydraulic fluid	Argon Helium ^{Note 1)} Turbine oil Hydraulic fluid	Carbon dioxide (CO ₂) (0.7 MPa or more)

Table 2

Note 1) Kinematic viscosity 40 to 100 mm²/s

Caution

This product cannot be used for water application.

2.4 Flow characteristics

Model	Measured by air		Measured by water ^{Note)}	
	C [dm ³ /(bar·s)]	b	Cv	Av x 10 ⁻⁶ m ²
VNA1□□□-6A	3.5	0.35	0.88	25
VNA1□□□-8A	5.9	0.24	1.5	41
VNA1□□□-10A	7.9	0.16	1.9	51
VNA2□□□-10A	16	0.35	3.8	110
VNA2□□□-15A	23	0.25	4.8	130
VNA3□□□-20A	34	0.16	7.5	210

Table 3 Note) This product cannot be used for water application.

2 Specifications - continued

Model	Cv	Effective area (mm ²)
VNA4□□□-25A	12	220
VNA5□□□-32A	18	320
VNA6□□□-40A	28	500
VNA7□□□-50A	43	770

Table 4

2.5 Weight (kg)

Model	Air operated	External pilot solenoid
VNA1□□□-6A	0.1	0.2
VNA1□□□-8A		
VNA1□□□-10A		
VNA2□□□-10A	0.3	0.4
VNA2□□□-15A		
VNA3□□□-20A	0.5	0.6
VNA4□□□-25A	0.8	0.9
VNA5□□□-32A	1.3	1.4
VNA6□□□-40A	2.1	2.2
VNA7□□□-50A	3.1	3.2

Table 5

2.6 Port size

VNA Series	Port 1(A), 2(B)	Port 12 (P1) Port 10 (P2) (If available)
	Threaded Fitting size (Rc, G, NPT or NPTF)	Threaded Fitting size (Rc)
VNA1□□□ - 6A	1/8	1/8
VNA1□□□ - 8A	1/4	1/8
VNA1□□□ - 10A	3/8	1/8
VNA2□□□ - 10A	3/8	1/8
VNA2□□□ - 15A	1/2	1/8
VNA3□□□ - 20A	3/4	1/8
VNA4□□□ - 25A	1	1/8
VNA5□□□ - 32A	1 1/4	1/8
VNA6□□□ - 40A	1 1/2	1/4
VNA7□□□ - 50A	2	1/4

Table 6

2.7 Symbols

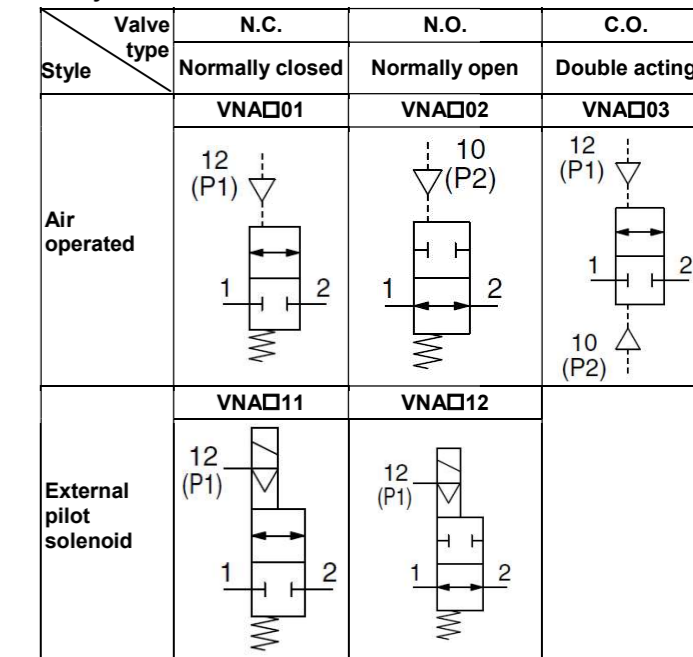

Table 7

Caution

Special products might have specifications different from those shown in this section. Contact SMC for specific drawings. These drawings will give the appropriate specification details and compliance with the safety principles of ISO 13849, if applicable.

3 Installation

3.1 Installation

Warning

- Do not install the product unless the safety instructions have been read and understood.
- With external pilot solenoids, the pilot solenoid valves are not splash proof specification so take care not to get fluid on it when performing maintenance.

3.2 Environment

Warning

- Do not use in an environment where corrosive gases, chemicals, salt water or steam are present.
- Do not use in an explosive atmosphere.
- Do not expose to direct sunlight. Use a suitable protective cover.
- Do not install in a location subject to vibration or impact. Check the product specifications.
- Do not mount in a location exposed to radiant heat.

3.3 Piping

Caution

- Before piping make sure to clean up chips, cutting oil, dust etc.
- When installing piping or fittings, ensure sealant material does not enter inside the port. When using seal tape, leave 1.5 to 2 threads exposed on the end of the pipe/fitting.
- Tighten fittings to the specified tightening torque.
- Applied voltage
When electric power is connected to a solenoid valve, be careful to apply the proper voltage. Improper voltage may cause malfunction or coil damage.
- Confirm the connections.
After completing the wiring, confirm that the connections are correct.

Thread	Appropriate tightening torque (N·m)
Rc (PT) 1/8	7 to 9
Rc (PT) 1/4	12 to 14
Rc (PT) 3/8	22 to 24
Rc (PT) 1/2	28 to 30
Rc (PT) 3/4	28 to 30
Rc (PT) 1	36 to 38
Rc (PT) 1 1/4	40 to 42
Rc (PT) 1 1/2	48 to 50
Rc (PT) 2	48 to 50

Table 8

Warning

When high temperature fluids are used, use fittings and tubing with heat resistant features. (Self-align fittings, PTFE tubing, Copper tubing, etc.)

3.4 Lubrication

Caution

- SMC products have been lubricated for life at manufacture, and do not require lubrication in service.
- If a lubricant is used in the system, use turbine oil Class 1 (no additive), ISO VG32. Once lubricant is used in the system, lubrication must be continued because the original lubricant applied during manufacturing will be washed away.

3.5 Mounting

Warning

- Do not apply external force to the coil section.**
When tightening is performed, apply a wrench or other tool to the outside of the piping connection parts.
- Do not warm the coil assembly with a heat insulator, etc.**
Use tape, heaters, etc., for freeze prevention on the piping and body only. They can cause the coil to burn out.

3 Installation - continued

- Avoid sources of vibration, or adjust the arm from the body to the minimum length so that resonance will not occur.**

Caution

- Direction of mounting**
When replacing a valve, if an external pilot solenoid valve is mounted in the wrong direction, it may malfunction or leak air.

3.5.1 Bracket (Optional)

Valve series 1, 2, 3 and 4 can be mounted using a bracket (optional).

Thread	Appropriate tightening torque (N·m)
M4	1.5
M5	3.0
M6	5.2

Table 9

For details, refer to section 6 Outline Dimensions.

3.6 Electrical connection

Caution

- When DC power is connected to a solenoid valve equipped with light and/or surge voltage suppressor, check for polarity indications.
- For polarity indications:
No diode to protect polarity: if polarity connection is wrong, the diode in the valve or switching device at control equipment or power supply may be damaged.
With diode to protect polarity: if polarity connection is wrong, the valve does not switch.

DIN connector:

- Loosen the fixing screw and remove the connector housing from the terminal spades on the solenoid.
- Remove the housing screw and insert a screwdriver into the slot on the underside of the DIN cap and carefully remove the block.
- Insert the cable through the gland nut, washer, grommet and housing.
- Loosen the terminal screws on the block and insert the stripped ends

- of the leads. Secure each lead by re-tightening the appropriate terminal screw.
- Tighten the housing gland nut to secure the cable.
- Reassemble the DIN connector in reverse order of removal.

Connections for DIN connector are shown in Figure 1:

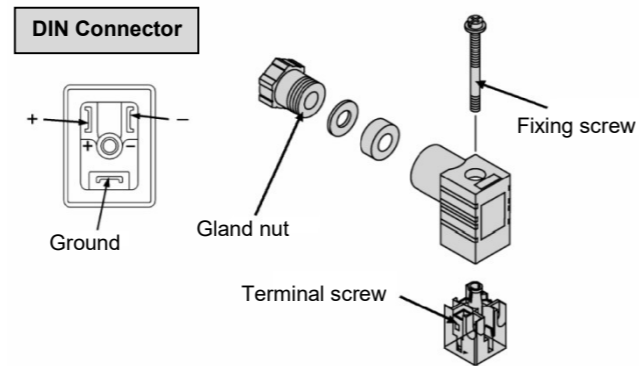

Figure 1

3.7 External Pilot

Caution

- Pilot port piping
12 (P1) and 10 (P2) piping should be as follows according to the model.

Port	VNA□01□	VNA□02□	VNA□03□	VNA□1 ¹ / ₂ □
12 (P1)	External pilot	Bleed port	External pilot (*)	External pilot
10 (P2)	Bleed port	External pilot	External pilot (*)	Pilot exhaust

Table 10

3 Installation - continued

- (*) If the pilot air is not supplied, the valve position will not be held. Pressurize Port 12 (P1) or Port 10 (P2) when using the product.

Installing a silencer to the exhaust port and the bleed port is recommended for noise reduction and for dust entry prevention.

3.8 Use with Air-hydro Unit

Warning

- Piping**
Surge pressure is generated between the cylinder and the VNA during intermediate stoppage. To directly thread in the cylinder, use durable fittings (Stainless steel square nipples, etc.) instead of ductile iron fittings (JIS B 2301) or steel pipe fittings (JIS B 2302). When VNA is installed away from the cylinder, use a high-pressure rubber hose (JIS B 6349) instead of steel pipe, when possible.
- Air bleeding**
Series VNA valves have no air bleeding port. Bleed air comes from the middle piping. Bleeding by a vacuum pump is more effective.
- Hydraulic fluid**
Turbine oil, Grade 1 ISO VG32, with petroleum hydraulic fluid is recommended.
- Speed control valve**
The combination shown in the following table is recommended for best performance of the series VNA. (Piping: JIS K 6349 high pressure hose)

Combination between Series-VNA and Speed controller (Series AS)

	VNA	AS	Piping (I.D.)
10A	VNA111	AS420-03	3/8B (ø9.5)
15A	VNA211	AS420-04	1/2B (ø12.7)
20A	VNA311	AS500-06	3/4B (ø19.1)
25A	VNA411	AS600-10	1B (ø25.4)
32A	VNA511	AS800-12	1 1/4B (ø31.8)
40A	VNA611	AS900-14	1 1/2B (ø38.1)
50A	VNA711	AS900-20	2B (ø50.8)

Table 11

4 Settings

4.1 Manual Override

Warning

Since connected equipment will operate when the manual override is activated, confirm that conditions are safe prior to activation.

4.1.1 Non-locking push type

VNA1-4: See Figure 1. Push on the manual override button using a small-bladed screwdriver until it stops ON.

Hold this position for the duration of the check (ON position).

Release the button and the override will re-set to OFF position.

VNA5-7: No tool needed. See Figure 2.

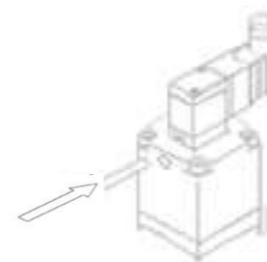

Figure 1

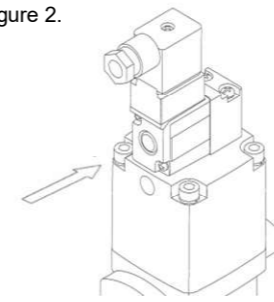

Figure 2

4.1.2 Push-locking slotted type

- To lock**
Using a small-bladed screwdriver in the slot, push the manual override button until it stops.
Turn the override button 90° in the direction of the arrow until it stops (ON position).
Remove the screwdriver.

Warning

In this position the manual override is in the locked 'ON' position.

4 Settings – continued

- To unlock**
Place a small-bladed screwdriver in the slot and push the manual override button.
Turn the override button 90° in the reverse direction of the arrow.
Remove the screwdriver and the manual override will re-set to the OFF position.

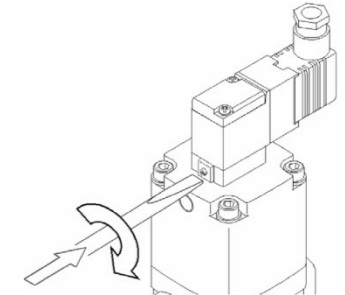

Figure 3

4.2 Continuous energization

Warning

Extended periods of continuous energization
If a valve is continuously energized for long periods, heat generation of the coil may result in reduced performance and shorter service life. This may also have an adverse effect on the peripheral equipment in proximity. Should a valve be continuously energized for long periods, or its daily energized state exceeds its non-energized state, please use an energy saving type AC, energizing for long periods of time continuously, select the air-operated valve and use the continuous duty type of the VT307 for a pilot valve.

5 How to Order

Seal material

A	NBR seals
B	FKM seals
C	EPR seals

Refer to "Table (1)" for availability

Thread type

Nil	Rc
F	G
N	NPT
T	NPTF

Bracket (Valve size: 1/2/3/4.)

Nil	None
B ^{Note)}	With bracket

Note) Only valve sizes 1, 2, 3 and 4.
Shipped after assembled at our factory.
Bracket part no.
Valve size 1: VN1-A16 (with thread)
Valve sizes 2 to 4: VN□-16

Air operated
VNA 2 0 1 A - □ 15A - □

External pilot solenoid
VNA 2 1 1 A - □ 15A - 1 T □ - □ - □

Valve size

Symbol	Orifice dia. (mm)	Symbol			Symbol	Port size Rc
		1	2	3 ^{Note)}		
		N.C.	N.O.	C.O.		
1	Ø10	●	●	●	6A	1/8
		●	●	●	8A	1/4
		●	●	●	10A	3/8
2	Ø15	●	●	●	10A	3/8
		●	●	●	15A	1/2
3	Ø20	●	●	●	20A	3/4
4	Ø25	●	●	●	25A	1
5	Ø32	●	●	●	32A	1 1/4
6	Ø40	●	●	●	40A	1 1/2
7	Ø50	●	●	●	50A	2
Validated		●	●	-		

Note) Air operated only

Rated voltage

Symbol	Rated voltage	Validated
1	100 V AC 50/60 Hz	-
2	200 V AC 50/60 Hz	-
3 ^{Note 1)}	110 V AC 50/60 Hz	-
4 ^{Note 1)}	220 V AC 50/60 Hz	-
5	24 V DC	●
6 ^{Note 1)}	12 V DC	●
7 ^{Note 1)}	240 V AC 50/60 Hz	-

Note 1) Semi-standard
Note 2) For other rated voltages, please consult with SMC.

CE-compliant

Symbol	CE-compliant	Validated
Nil	-	-
Q	CE-compliant	●

Note) CE-compliant: For D or DZ only

Manual override

Valve size 1 to 4		
Nil: Non-locking push type	A: Non-locking push type A ^{Note)} (projecting)	B: Slotted locking type B ^{Note)} (tool required)
Validated	●	●

Note) Semi-standard

Electrical entry/With light/surge voltage suppressor

Symbol	Electrical entry	Valve size 1 to 4	Valve size 5 to 7	Validated
G	Grommet	●	●	-
GS	Grommet with surge voltage suppressor	●	●	-
E	Grommet terminal	●	-	-
EZ	Grommet terminal with light/surge voltage suppressor	●	-	-
T	Conduit terminal	●	-	-
TZ	Conduit terminal with light/surge voltage suppressor	●	-	-
D	DIN terminal	●	●	●
DZ	DIN terminal with light/surge voltage suppressor	●	●	●

CE-compliant

Symbol	Electrical entry	Valve size 1 to 4	Valve size 5 to 7	Validated
D	DIN terminal	●	●	●
DZ	DIN terminal with light/surge voltage suppressor	●	●	●

Table (1): Applicable Fluids

Model	VNA□□□□A (Valve material: NBR seal)	VNA□□□□B (Valve material: FKM seal)	VNA□□□□C (Valve material: EPR seal)
Fluid	Air (Standard, Dry) Carbon dioxide (CO ₂)(Less than 0.7 MPa) Nitrogen gas (N ₂) Turbine oil ^{Note)} Hydraulic fluid	Argon Helium ^{Note)} Turbine oil Hydraulic fluid	Carbon dioxide (CO ₂) (0.7 MPa or more)

Note) Kinematic viscosity 40 to 100 mm²/s

6 Outline Dimensions (mm)

6.1 Port Size: 6A, 8A, 10A

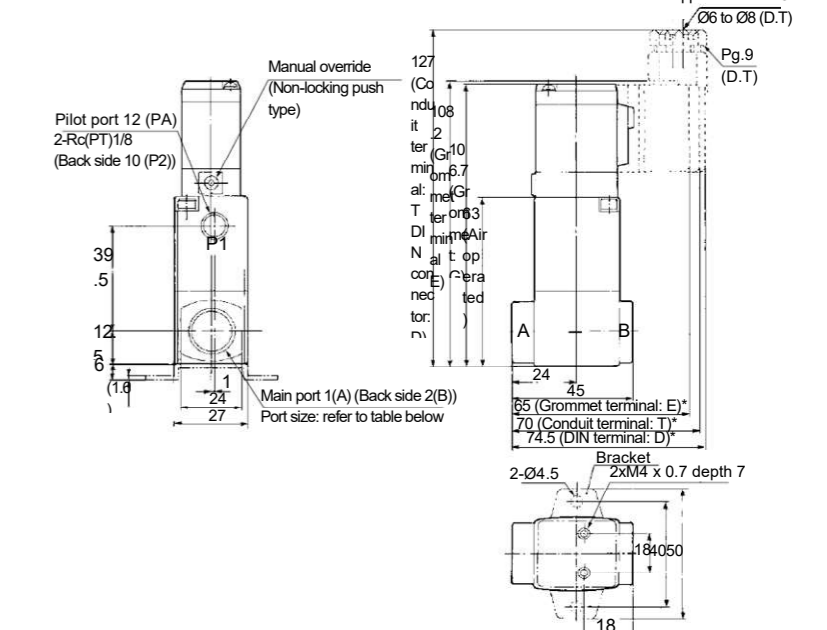

* In the case of "EZ" or "TZ", the length is longer by 10 mm.
For "DZ", the length is longer by 17 mm.

Table 12

Model	Main Port (Rc(PT))
VNA1□□□-6A	1/8
VNA1□□□-8A	1/4
VNA1□□□-10A	3/8

6.2 Port Size: 10A, 15A, 20A, 25A

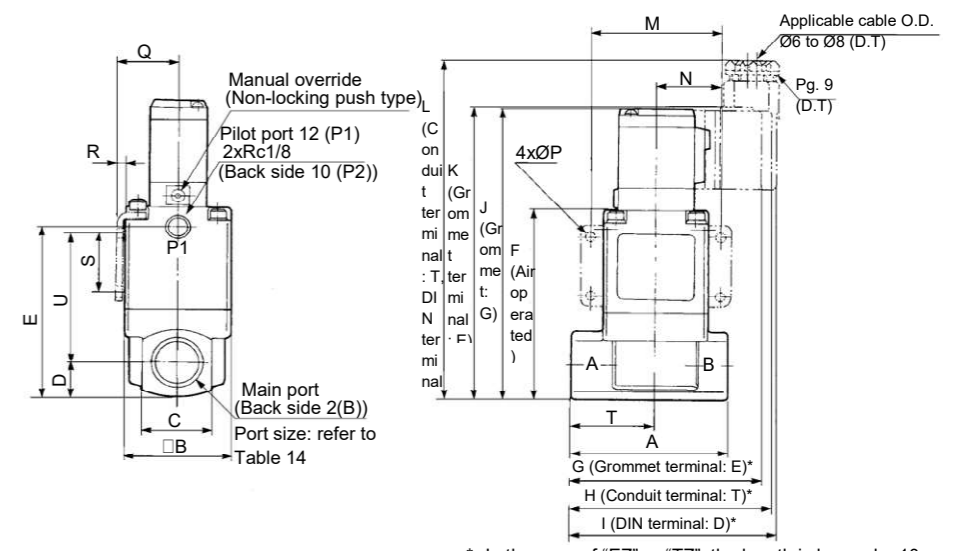

* In the case of "EZ" or "TZ", the length is longer by 10 mm.
For "DZ", the length is longer by 17 mm.

Table 13

Model	Main port 1(A), 2(B)	A	B	C	D	E	F	G	H	I
VNA2□□□-10A	3/8	63	42	28	14	72.5	80.5	75	80	84.5
VNA2□□□-15A	1/2									
VNA3□□□-20A	3/4	80	50	35	17.5	84	92	84	89	93.5
VNA4□□□-25A	1	90	60	40	20	100	108	90	95	99.5

Table 13

Model	J	K	L	M	N	P	Q	R	S	T	U
VNA2□□□-10A	124	125.5	144.5	52	26	4.5	24.3	2.3	25	34	55
VNA2□□□-15A											
VNA3□□□-20A	135.5	137	156	62	31	5.5	28.3	2.3	30	43	60.5
VNA4□□□-25A	151.5	153	172	72	36	6.5	33.3	2.3	35	49	73

6 Outline Dimensions (mm) – continued

6.3 Port size: 32A, 40A, 50A

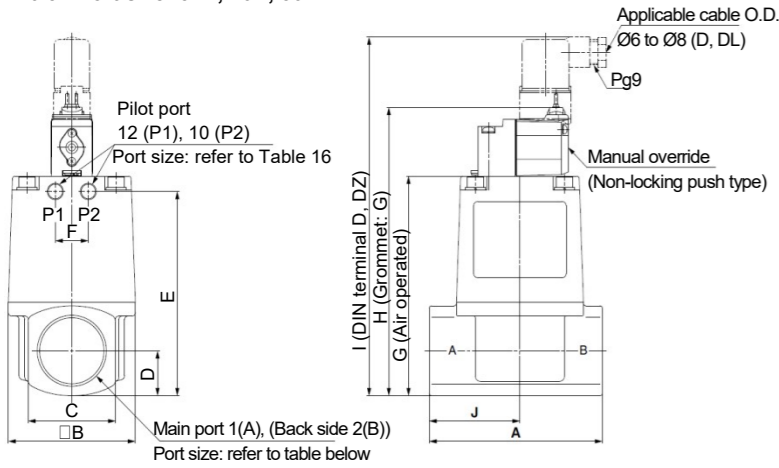

Model	Main port 1(A), 2(B)	Pilot port 12(P1), 10(P2)	A	B	C	D	E	F	G	H	I	J
VNA5□□□-32A	1 1/4	1/8	105	77	53	26.5	120.5	20	129.5	170.1	211.5	55
VNA6□□□-40A	1 1/2	1/4	120	96	60	30	137	24	147	187.6	229	63
VNA7□□□-50A	2	1/4	140	113	74	37	160	24	170	210.6	252	74

Table 14

6.4 Bracket (Optional)

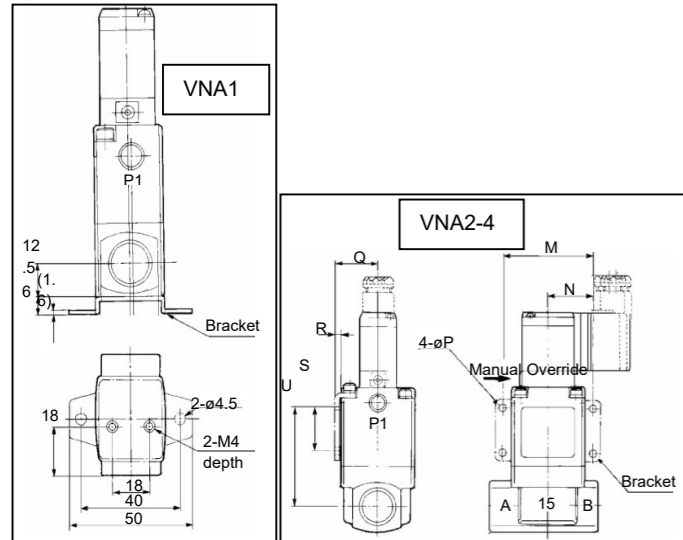

Model	Main port Rc	M	N	P	Q	R	S	U
VNA2□□□-10A	3/8	52	26	4.5	24.3	2.3	25	55
VNA2□□□-15A	1/2	62	31	5.5	28.3	2.3	30	60.5
VNA3□□□-20A	3/4	72	36	6.5	33.3	2.3	35	73
VNA4□□□-25A	1							

Table 15

7 Maintenance

7.1 General Maintenance

Caution

- Not following proper maintenance procedures could cause the product to malfunction and lead to equipment damage.
- If handled improperly, compressed air can be dangerous. Maintenance of pneumatic systems should be performed only by qualified personnel.
- Before performing maintenance, turn off the power supply and be sure to cut off the supply pressure. Confirm that the air is released to atmosphere.
- After installation and maintenance, apply operating pressure and power to the equipment and perform appropriate functional and leakage tests to make sure the equipment is installed correctly.
- If any electrical connections are disturbed during maintenance, ensure they are reconnected correctly and safety checks are carried out as required to ensure continued compliance with applicable national regulations.
- Do not make any modification to the product.
- Do not disassemble the product, unless required by installation or maintenance instructions.
- Drain
Remove condensate from the filter bowl on a regular basis.

7.2 Replacing Spare Parts

7.2.1 Replacing Plate Assembly and valve element

1. Remove body mounting screws
2. Apply sufficient air pressure to pilot port to release plate assembly.
3. Place well fitting slotted screwdriver into slot in piston rod and unscrew seal mounting nut with spanner.
4. If spring pin is used, slide pin out and remove valve element.
5. Slide off valve element, washer and plate assembly.
6. Refitting is reverse of removal (use correct tightening torque).

7.2.2 Replacing Pilot Valve Assembly

1. Remove pilot valve mounting screws.
2. Remove pilot valve (retain DIN plug if necessary).
3. Fitting of new pilot valve is reverse of removal assembly (use correct tightening torque).

Caution

- Never remove inner circlip from valve.
- When replacing external pilot valve, ensure it is mounted in the correct direction. If mounted in the wrong direction, it may malfunction or leak air.

Tightening Torque (N·m)

Valve Size	VNA1	VNA2	VNA3	VNA4	VNA5	VNA6	VNA7
Seal Mounting Nut	0.315	1.5	1.5	1.5	1.5	2.6	6.2
Piston Cover Mounting Screw	0.76	0.76	1.5	2.6	2.6	6.2	6.2
Pilot Valve Mounting Screw	0.315	0.315	0.315	0.315	0.76	0.76	0.76

Table 16

7 Maintenance - continued

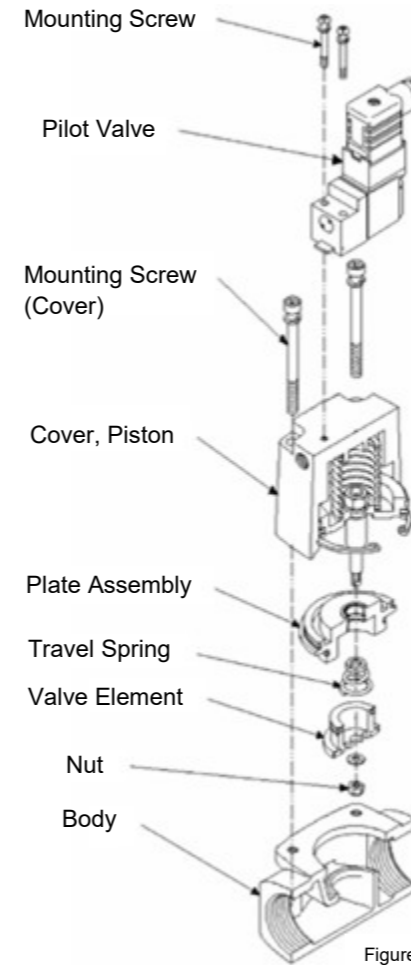

Figure 4

7.3 Filters and strainers

- Be careful regarding clogging of filters and strainers.
- Replace filter elements after one year of use, or earlier, if the pressure drop reaches 0.1 MPa.
- Clean strainers when the pressure drop reaches 0.1 MPa.

8 Limitations of Use

8.1 Limited warranty and Disclaimer/Compliance Requirements

- The product used is subject to the following “Limited warranty and Disclaimer” and “Compliance Requirements”. Read and accept them before using the product.

Limited warranty and Disclaimer

1) The warranty period of the product is 1 year in service or 1.5 years after the product is delivered, whichever is first⁽¹⁾. Also, the product may have specified durability, running distance or replacement parts. Please consult your nearest sales branch.

2) For any failure or damage reported within the warranty period which is clearly our responsibility, a replacement product or necessary parts will be provided.

This limited warranty applies only to our product independently, and not to any other damage incurred due to the failure of the product.
3) Prior to using SMC products, please read and understand the warranty terms and disclaimers noted in the specified catalogue for the particular products.

⁽¹⁾ Vacuum pads are excluded from this 1 year warranty.

A vacuum pad is a consumable part, so it is warranted for a year after it is delivered. Also, even within the warranty period, the wear of a product due to the use of the vacuum pad or failure due to the deterioration of rubber material are not covered by the limited warranty.

8 Limitations of Use - continued

- **Compliance Requirements** 1) The use of SMC products with production equipment for the manufacture of weapons of mass destruction (WMD) or any other weapon is strictly prohibited.
2) The exports of SMC products or technology from one country to another are governed by the relevant security laws and regulations of the countries involved in the transaction. Prior to the shipment of a SMC product to another country, assure that all local rules governing that export are known and followed.

Caution

- **SMC products are not intended for use as instruments for legal metrology.**
Measurement instruments that SMC manufactures or sells have not been qualified by type approval tests relevant to the metrology (measurement) laws of each country.
Therefore, SMC products cannot be used for business or certification ordained by the metrology (measurement) laws of each country.

Warning

- Do not exceed any of the specifications laid out in section 2.
- Any use in an ISO 13849 system must be within the specified limits and application conditions. The user is responsible for the specification, design, implementation, validation and maintenance of the safety system (SRP/CS)

9 Contacts

AUSTRIA	SMC Pneumatik GmbH, Girakstrasse 8, AT-2100 Korneuburg, Austria
BELGIUM	SMC Pneumatics N.V./S.A. Nijverheidsstraat 20, B-2160 Wommelgem, Belgium
BULGARIA	SMC Industrial Automation Bulgaria EOOD, Business Park Sofia, Building 8-6th floor, BG-1715 Sofia, Bulgaria
CROATIA	SMC IndustrijskaAutomatikad.o.o. ZagrebačkaAvenija 104,10 000 Zagreb
CZECH REP.	SMC Industrial Automation CZ s.r.o. Hudcova 78a, CZ-61200 Brno, Czech Republic
DENMARK	SMC Pneumatik A/S,Egeskovvej 1, DK-8700 Horsens, Denmark
ESTONIA	SMC Pneumatics Estonia OÜ,Laki 12, EE-10621 Tallinn, Estonia
FINLAND	SMC Pneumatics Finland Oy, PL72, Tiistiniityntie 4, SF-02031 Espoo, Finland
FRANCE	SMC Pneumatique SA.1, Boulevard de Strasbourg, Parc Gustave Eiffel, Bussy Saint Georges, F-77607 Marne La ValleeCedex 3, France
GERMANY	SMC Pneumatik GmbH, Boschring 13-15, 63329 Egelsbach, Germany
GREECE	SMC Italia Hellas Branch, Anagenniseos 7-9-P.C. 14342 N.Philadelphia, Athens, Greece
HUNGARY	SMC Hungary IpariAutomatizálásiKft.Torbágy u. 19, HU-2045 Törökbálint, Hungary
IRELAND	SMC Pneumatics (Ireland) Ltd.2002 Citywest Business Campus, Naas Road, Saggart, Co. Dublin, Ireland
ITALY	SMC Italia S.p.A.Via Garibaldi 62, I-20061Carugate, (Milano), Italy
LATVIA	SMC Pneumatics Latvia SIA, Dzelzavas str. 120g, Riga, LV-1021, Latvia
LITHUANIA	UAB "SMC Pneumatics", Oslo g. 1, LT-04123 Vilnius, Lithuania

NETHERLANDS	SMC Pneumatics B.V.De Ruyterkade 120, NL-1011 AB Amsterdam, the Netherlands
NORWAY	SMC Pneumatics Norway AS, Vollsveien 13 C, GranfosNæringspark, N-1366 Lysaker, Norway
POLAND	SMC Industrial Automation, Polska Sp z o.o. 02-826 Warszawa, ul. Poloneza 89, Poland
PORTUGAL	SMC España S.A. Zuazobidea 14, 01015 Vitoria, Spain
ROMANIA	SMC Romania S.r.l. StrFrunzei 29, Sector 2, Bucharest, Romania
RUSSIA	SMC Pneumatik LLC. Business centre, building 3, 15 Kondratjevskij prospect, St.Petersburg, Russia, 195197
SLOVAKIA	SMC PriemyselnáAutomatizáciaSpols.r.o. Fantranská 1223, Teplickanadvahom, 01301, Slovakia
SLOVENIA	SMC IndustrijskaAvtomatikad.o.o. Mirnskacesta 7, SLO-8210 Trebnje, Slovenia
SPAIN	SMC España S.A. Zuazobidea 14, 01015 Vitoria, Spain
SWEDEN	SMC Pneumatics Sweden AB,Ekhagsvägen 29-31, SE-141 71 Segeltorp, Sweden
SWITZERLAND	SMC Pneumatik AG,Dorfstrasse 7, Postfach, 8484 Weisslingen, Switzerland
TURKEY	SMC PnömatikSanayiTicaretveServis A.Ş. GülbaharCaddesi, Aydın Plaza, No: 9/4 Güneşli – 34212 , Istanbul
UK	SMC Pneumatics (U.K.) Ltd. Vincent Avenue, Crownhill, Milton Keynes, Buckinghamshire MK8 0AN, United Kingdom

SMC Corporation

URL : [http:// www.smcworld.com](http://www.smcworld.com) (Global) [http:// www.smceu.com](http://www.smceu.com) (Europe)
'SMC Corporation, Akihabara UDX15F, 4-14-1, Sotokanda, Chiyoda-ku, Tokyo 101 0021

Specifications are subject to change without prior notice from the manufacturer.

© 2016 SMC Corporation All Rights Reserved.

Template DKP50047-F-085D